

# HICONICS

A member of Midea group

## Quick Guide

Please scan the following QR code for Three Phase RESS User Manual



Please scan the following QR code to download the Solarman Smart and Solarman Business APP



SOLARMAN Business APP



SOLARMAN Smart APP

Before installing the camera, please read through the user manual in order to learn the product information and safety precautions. The Company does not provide warranty services for any damage caused by the failure in storing, handling, installing and using the equipment according to this document and user manual. We may update this document irregularly due to product version upgrading or other reasons. This document is used for use guidance, and all statements, information and suggestions contained herein do not constitute any guarantee, either expressly or in an implied manner, unless otherwise specified.

### 01 Installation Overview

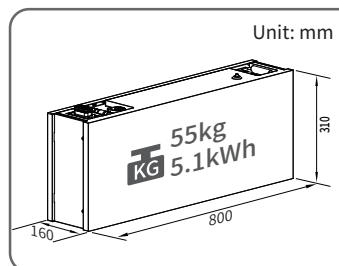
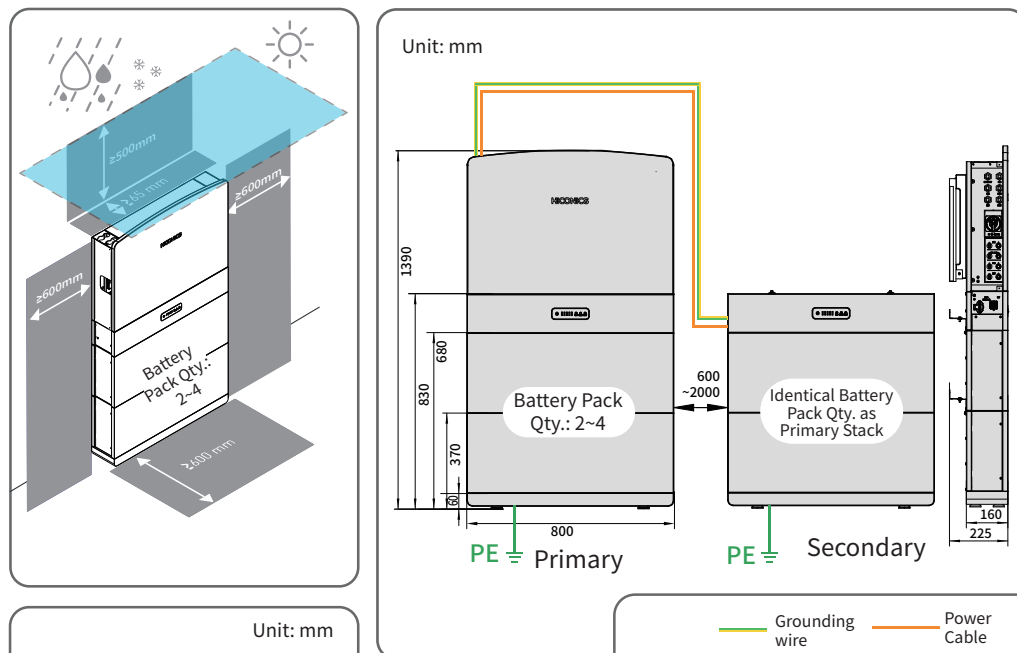

### 02 Drilling Holes for Battery Pack Positioning

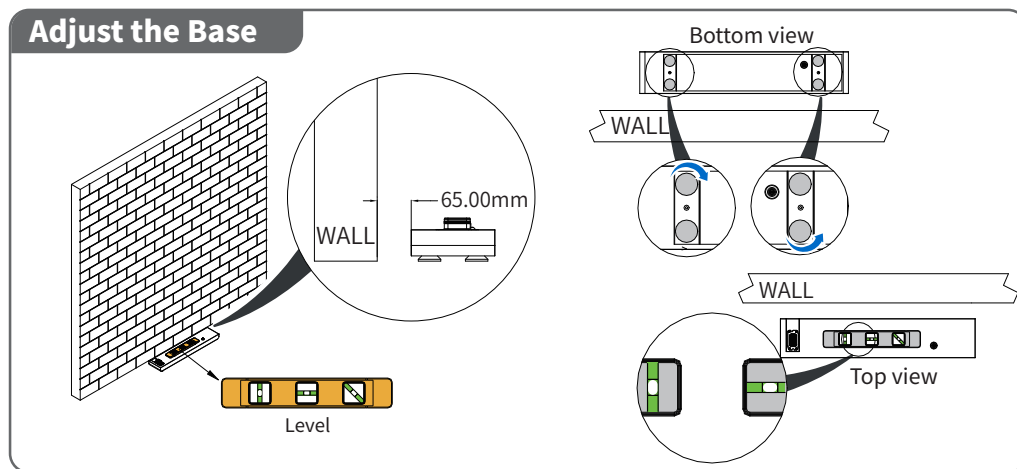

### Drilling positioning

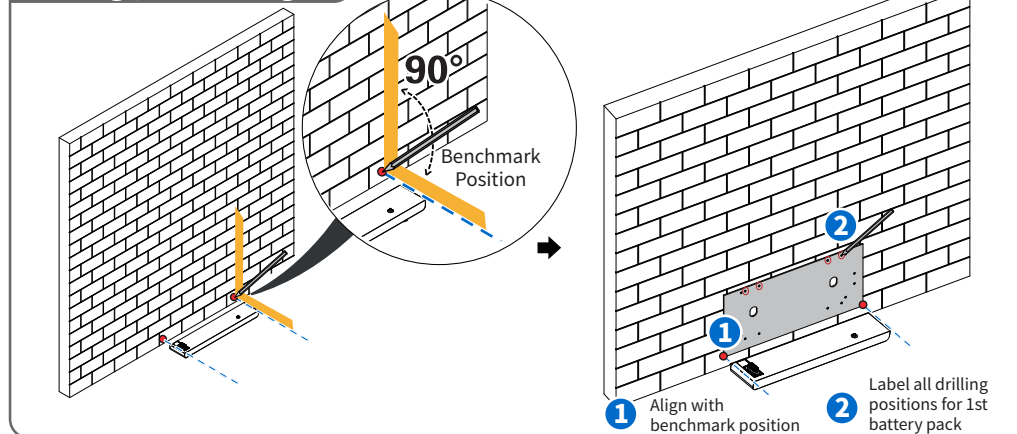

### 03 Installing Battery Pack

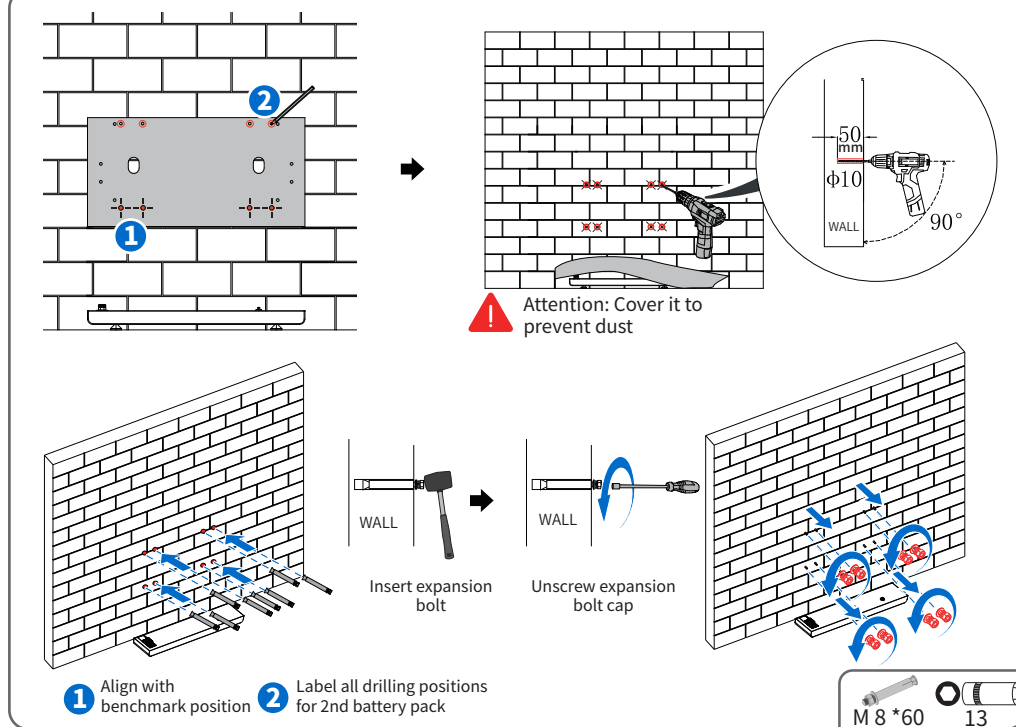
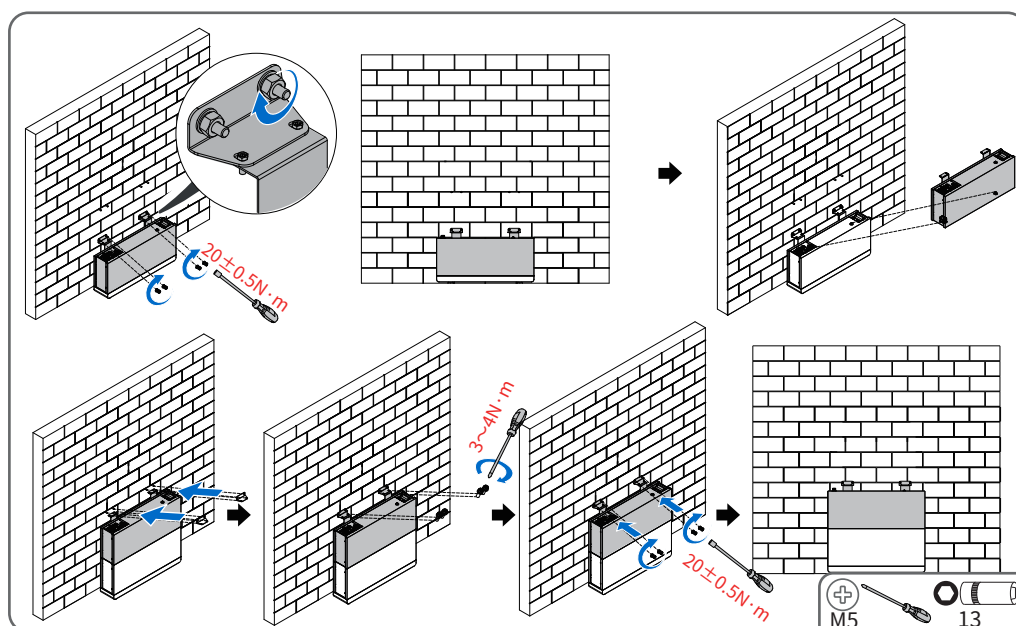
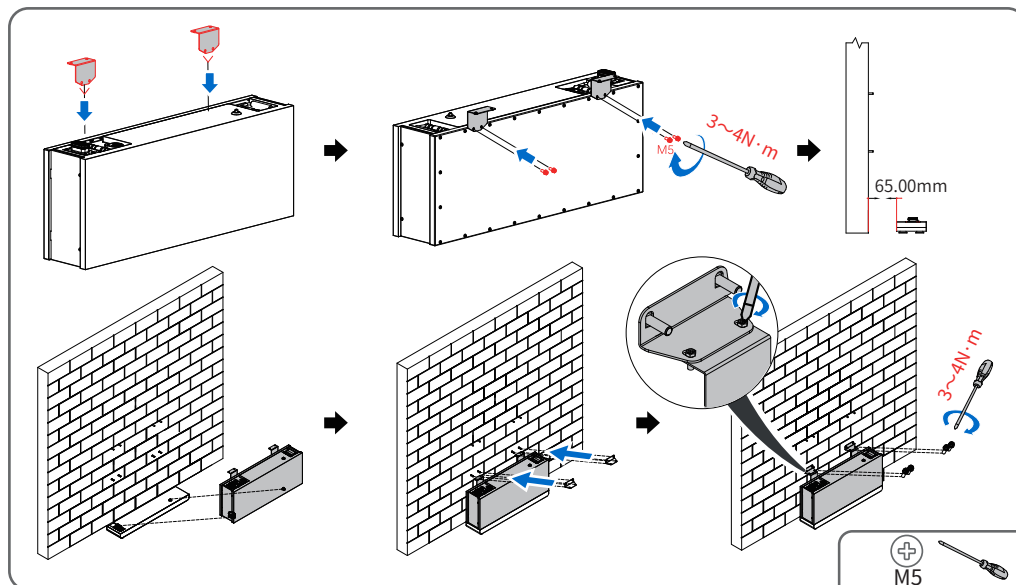

### 04 Installing BMS Control Box

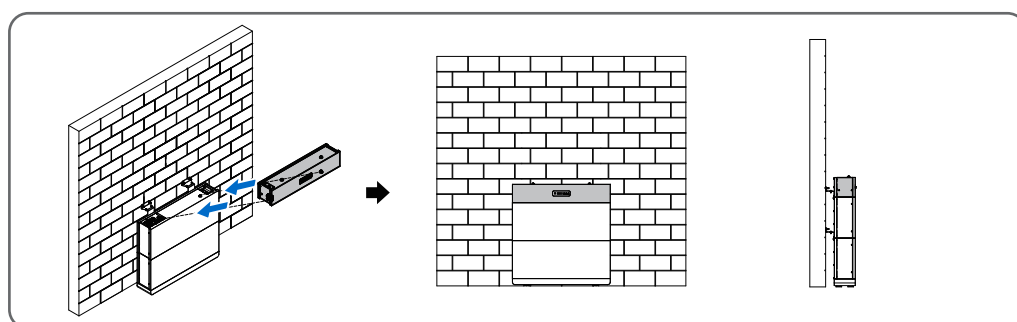

### 05 Drilling Holes for Inverter Positioning

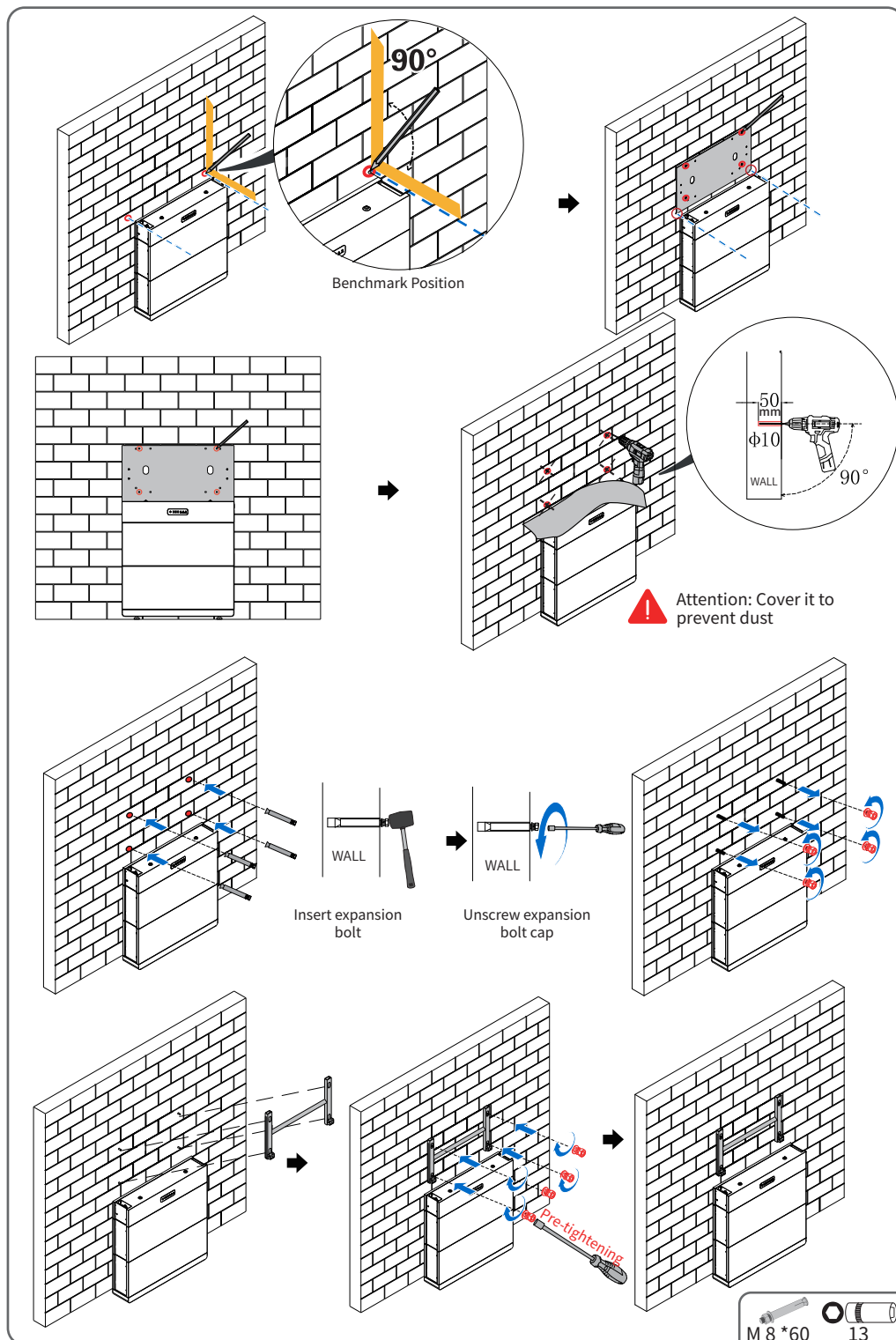

## 06 Installing Inverter

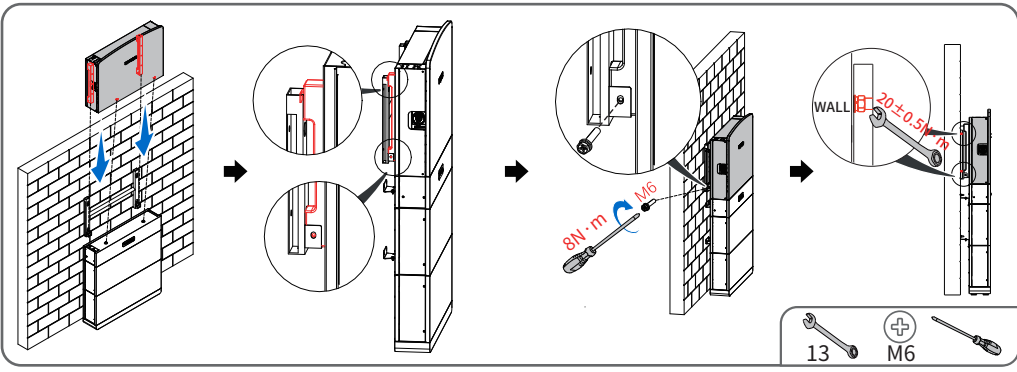

## 07 Connection of BMS Control Box and Inverter

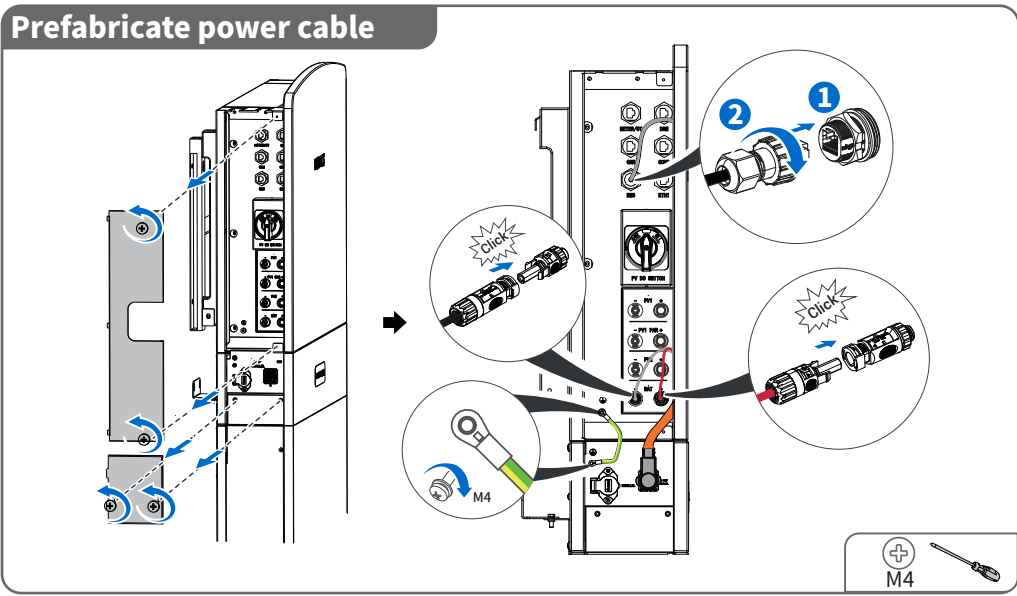

## 08 AC Connection

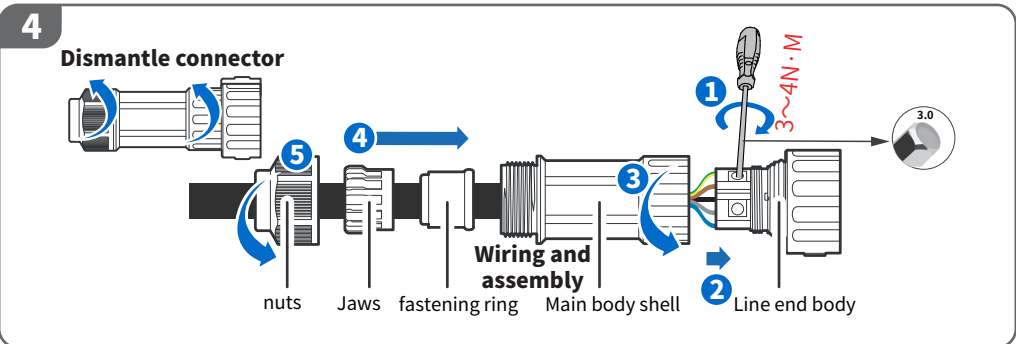
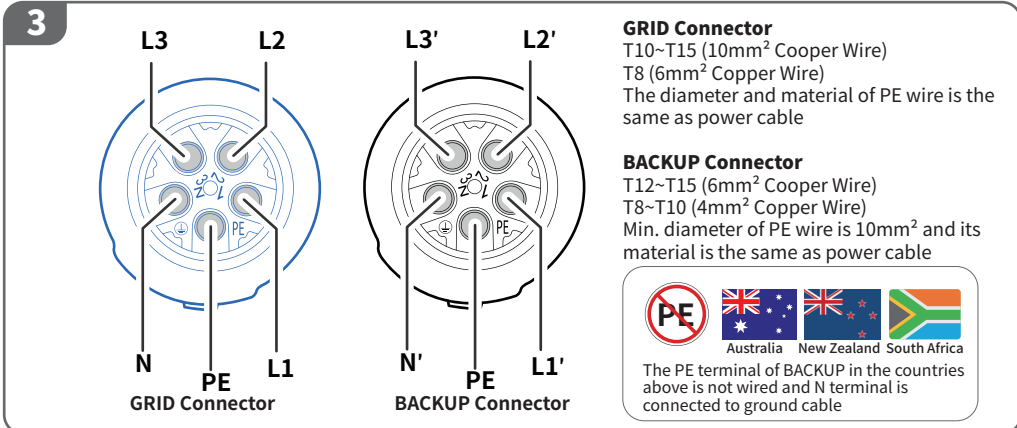
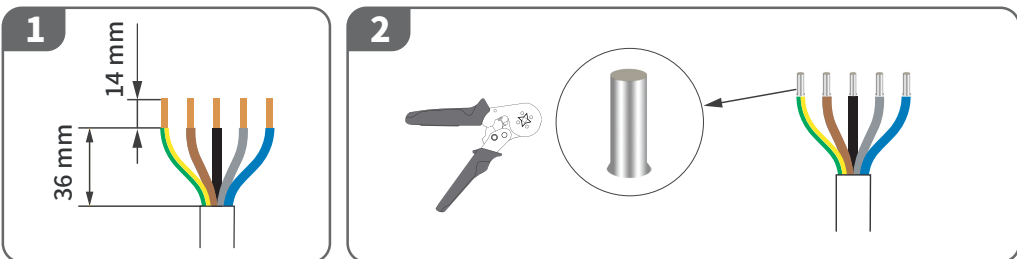

## 09 PV Connection

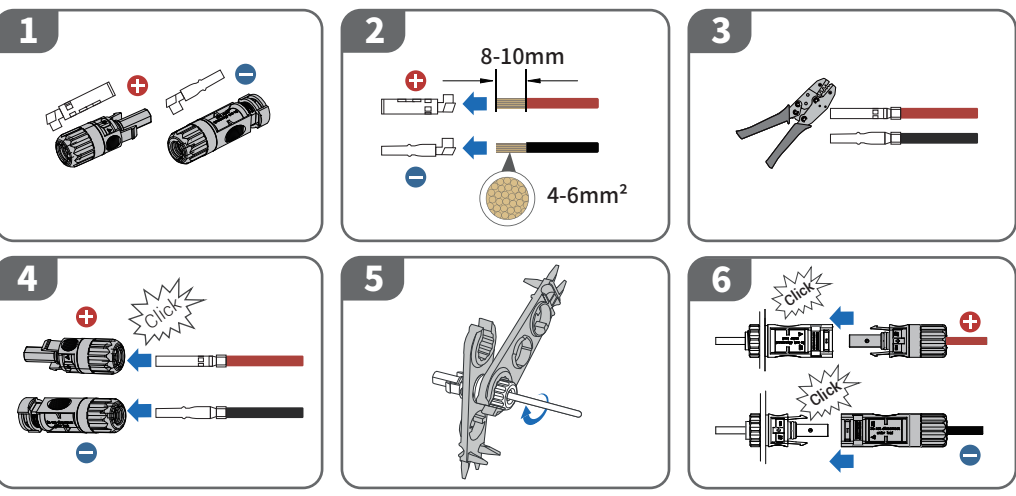

## 10 Connection of Communication Cable

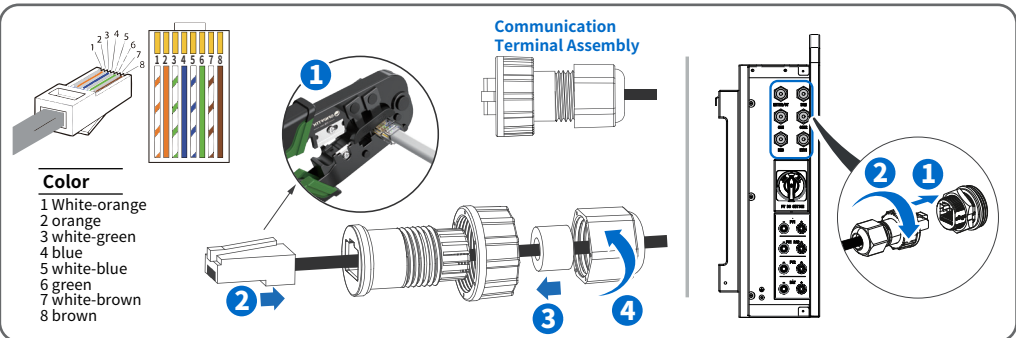

## 11 Connection of Metering

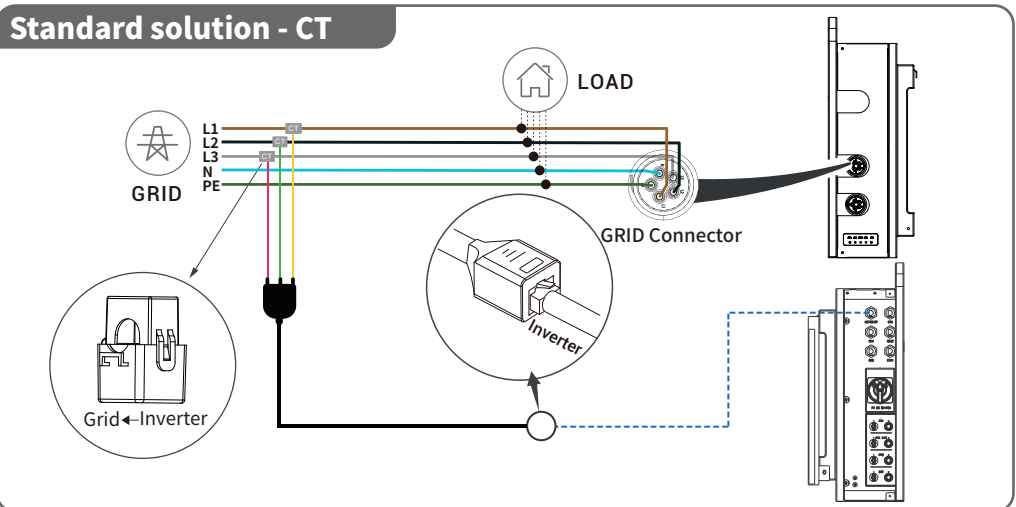

## Optional solution - Meter

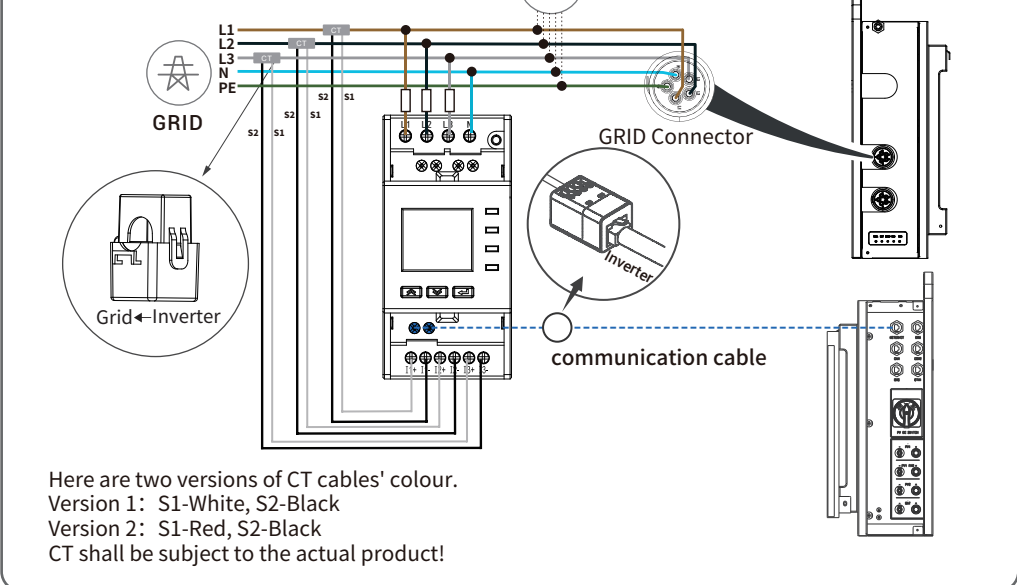

## 12 Overall Cable Connection

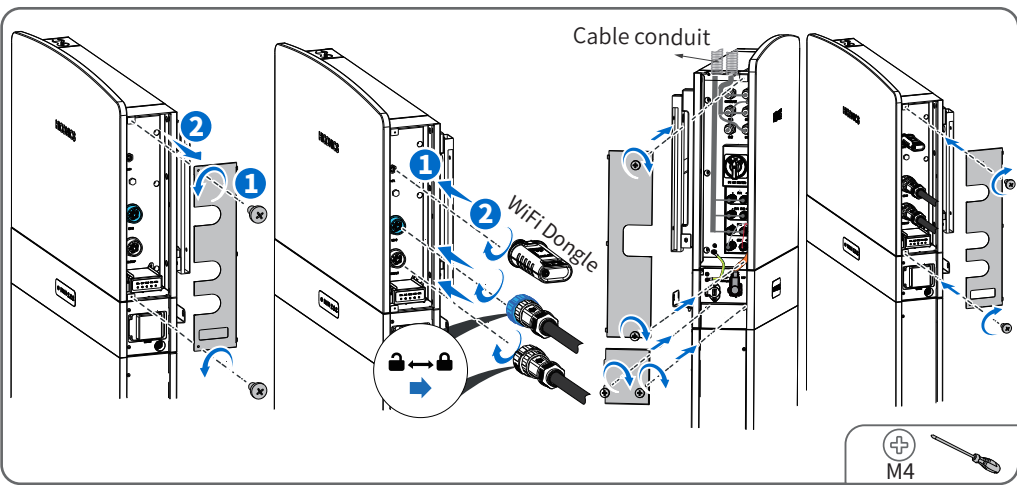

## 13 Installing the Parallel Machine

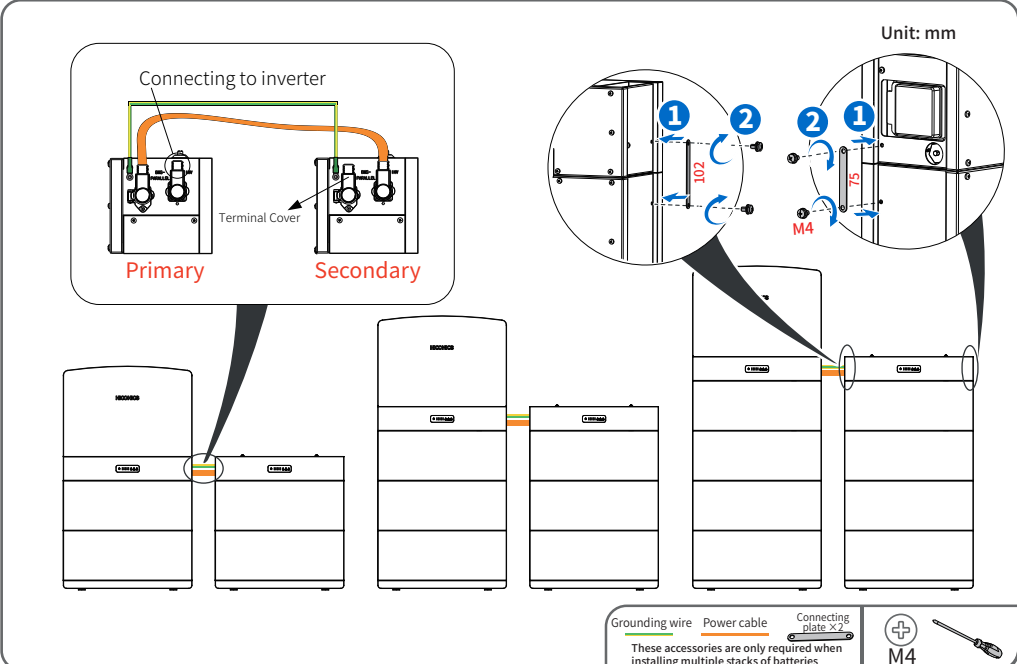

## 14 Power On/Off Operations

